

Spec. No.	INR18650-25R	Version No.	1.0	In-Young Jang
-----------	--------------	-------------	-----	---------------

# SPECIFICATION OF PRODUCT

**Lithium-ion rechargeable cell for power tools**

**Model name : INR18650-25R**

Spec. No.	INR18650-25R	Version No.	1.0	In-Young Jang
-----------	--------------	-------------	-----	---------------

## **Contents**

- 1.0. Scope
- 2.0. Description and model name
  - 2.1. Description
  - 2.2. Model name
- 3.0. Nominal specification
- 4.0. Outline dimensions
- 5.0. Appearance
- 6.0. Standard test conditions
  - 6.1. Environmental conditions
  - 6.2. Measuring equipments
- 7.0. Characteristics
  - 7.1. Standard charge
  - 7.2. Rapid charge
  - 7.3. Nominal discharge capacity
  - 7.4. Standard rated discharge capacity
  - 7.5. Initial internal impedance
  - 7.6. Temperature dependence of discharge capacity
  - 7.7. Temperature dependence of charge capacity
  - 7.8. Charge rate capabilities
  - 7.9. Discharge rate capabilities
  - 7.10. Cycle life
  - 7.11. Storage characteristics
  - 7.12. Status of the cell as of ex-factory
- 8.0. Mechanical Characteristics
  - 8.1. Drop test
  - 8.2. Vibration test
- 9.0. Safety
  - 9.1. Overcharge test
  - 9.2. External short-circuit test
  - 9.3. Reverse charge test
  - 9.4. Heating test
- 10.0. Warranty
- 11.0. Others
  - 11.1. Storage for a long time
  - 11.2. Others
- 12.0. Packing

## **Proper use and handling of lithium ion cells**

Handling precaution and prohibitions of lithium ion rechargeable cells and batteries

Samsung SDI emergency contact information

Additional remarks

Revision history

Spec. No.	INR18650-25R	Version No.	1.0	In-Young Jang
-----------	--------------	-------------	-----	---------------

### 1.0. Scope

This product specification has been prepared to specify the rechargeable lithium-ion cell ('cell') to be supplied to the customer by Samsung SDI Co., Ltd.

### 2.0. Description and model name

2.1 Description               lithium-ion rechargeable cell

2.2 Model name               INR18650-25R

### 3.0. Nominal specifications

Item	Specification
3.1 Nominal discharge capacity	2,500mAh Charge: 1.25A, 4.20V, CCCV 125mA cut-off, Discharge: 0.2C, 2.5V discharge cut-off
3.2 Nominal voltage	3.6V
3.3 Standard charge	CCCV, 1.25A, 4.20 ± 0.05 V, 125mA cut-off
3.4 Rapid charge	CCCV, 4A, 4.20 ± 0.05 V, 100mA cut-off
3.6 Charging time	Standard charge : 180min / 125mA cut-off Rapid charge: 60min (at 25°C) / 100mA cut-off
3.7 Max. continuous discharge (Continuous)	20A(at 25°C), 60% at 250 cycle
3.8 Discharge cut-off voltage End of discharge	2.5V
3.9 Cell weight	45.0g max
3.10 Cell dimension	Height : 64.85 ± 0.15mm Diameter : 18.33 ± 0.07mm
3.11 Operating temperature (surface temperature)	Charge : 0 to 50°C (recommended recharge release < 45°C) Discharge: -20 to 75°C (recommended re-discharge release < 60°C)
3.12 Storage temperature (Recovery 90% after storage)	1.5 year     -30~25°C (1*) 3 months    -30~45°C (1*) 1 month     -30~60°C (1*)

Note (1): If the cell is kept as ex-factory status (50±5% SOC, 25°C),  
the capacity recovery rate is more than 90% of 10A discharge capacity  
100% is 2,450mAh at 25°C with SOC 100% after formation.

Spec. No.	INR18650-25R	Version No.	1.0	In-Young Jang
-----------	--------------	-------------	-----	---------------

**4.0 Outline dimensions**

See the attachment (Fig. 1)

**5.0. Appearance**

There shall be no such defects as scratch, rust, discoloration, leakage which may adversely affect commercial value of the cell.

**6.0. Standard test conditions**

6.1 Environmental conditions

Unless otherwise specified, all tests stated in this specification are conducted at temperature  $25\pm 5^{\circ}\text{C}$  and humidity  $65\pm 20\%$ .

6.2 Measuring equipments

(1) Amp-meter and volt-meter

The amp-meter and volt-meter should have an accuracy of the grade 0.5mA and mV or higher.

(2) Slide caliper

The slide caliper should have 0.01 mm scale.

(3) Impedance meter

The impedance meter with AC 1kHz should be used.

**7.0. Characteristics**

7.1 Standard charge

This "Standard charge" means charging the cell CCCV with charge current 0.5CmA (1,250mA), constant voltage 4.2V and 125mA cut-off in CV mode at  $25^{\circ}\text{C}$  for capacity. .

7.2 Rapid charge

Rapid charge means charging the cell CCCV with charge current 4A and 100mA cut-off at  $25^{\circ}\text{C}$

7.3 Nominal discharge capacity

The standard discharge capacity is the initial discharge capacity of the cell, which is measured with discharge current of 500mA(0.2C) with 2.5V cut-off at  $25^{\circ}\text{C}$  within 1hour after the standard charge.

$$\text{Nominal discharge capacity} \geq 2,500\text{mAh}$$

Which complying to the minimum capacity of IEC61960 standard.

7.4 Standard rated discharge capacity

The standard rated discharge is the discharge capacity of the cell, which is measured with discharge current of 10A with 2.5V cut-off at  $25^{\circ}\text{C}$  within 1hour after the standard charge.

$$\text{Standard rated discharge capacity} \geq 2,450\text{mAh}$$

7.5 Initial internal impedance

Initial internal impedance measured at AC 1kHz after standard charge

$$\text{Initial internal impedance} \leq 18\text{m}\Omega$$

7.6 Temperature dependence of discharge capacity

Capacity comparison at each temperature, measured with discharge constant current 10A and 2.5V cut-off after the standard charge is as follows.

Discharge temperature				
-20 $^{\circ}\text{C}$	-10 $^{\circ}\text{C}$	0 $^{\circ}\text{C}$	25 $^{\circ}\text{C}$	60 $^{\circ}\text{C}$

Spec. No.	INR18650-25R	Version No.	1.0	In-Young Jang
-----------	--------------	-------------	-----	---------------

60%	75%	80%	100%	100%
-----	-----	-----	------	------

Note: If charge temperature and discharge temperature is not the same, the interval for temperature change is 3 hours.

Percentage index of the discharge at 25 °C at 10A (=2,450mAh) is 100%.

#### 7.7 Temperature dependence of charge capacity

Capacity comparison at each temperature, measured with discharge constant current 10A and 2.5V cut-off after the standard charge is as follows.

	Charge temperature					Discharge temperature
	0 °C	5 °C	25 °C	45 °C	50 °C	
Relative capacity	80%	90%	100%	95%	95%	25 °C

Note: If charge temperature and discharge temperature is not the same, the interval for temperature change is 3 hours.

Percentage index of the discharge at 25 °C at 10A (=2,450mAh) is 100%.

#### 7.8 Charge rate capabilities

Discharge capacity is measured with constant current 10A and 2.5V cut-off after the cell is charged with 4.2V as follows.

	Charge condition	
Current	Standard 1.25A	Maximum rapid charge 4A
Cut-off	125mA	100mA
Relative Capacity	100%	98%

Note: Percentage index of the discharge at 25 °C at 10A (=2,450mAh) is 100%.

#### 7.9 Discharge rate capabilities

Discharge capacity is measured with the various currents in under table and 2.5V cut-off after the standard charge.

	Discharge condition				
Current	0.50A	5A	10A	15A	20A
Relative Capacity	100%	97%	100%	97%	95%

Percentage index of the discharge at 25 °C at 10A (=2,450mAh) is 100%.

#### 7.10 Cycle life

With standard charge and maximum continuous discharge.

Capacity after 250cycles,

Capacity  $\geq$  1,500mAh (60% of the nominal capacity at 25 °C)

#### 7.11 Storage characteristics

Standard rated discharge capacity after storage for 1 month at 60 °C from the standard charged state is  $\geq$  90% of the initial 10A discharge capacity at 25 °C

#### 7.12 Status of the cell as of ex-factory

The cell should be shipped in 50  $\pm$  5% charged state. In this case, OCV is from 3.600V to 3.690V.

Spec. No.	INR18650-25R	Version No.	1.0	In-Young Jang
-----------	--------------	-------------	-----	---------------

## 8.0. Mechanical Characteristics

### 8.1 Drop test

Test method: Cell(as of shipment or full charged) drop onto a concrete from 1.0m height at 3 sides.

Criteria: No leakage, Voltage decrease  $\leq 0.025V$ , AC iR increase  $\leq 1.0m\Omega$

### 8.2 Vibration test

Test method: As to the UN transportation regulation(UN38.3), for each axis (X and Y axis with cylindrical cells) 7Hz→200Hz→7Hz for 15min, repetition 12 times totally 3hours, the acceleration 1g during 7 to 18Hz and 8g (amplitude 1.6mm) up to 200Hz.

Criteria: No leakage, with less than 10mV of OCV drop

## 9.0. Safety

### 9.1 Overcharge test

Test method: To charge with 20A-20V at 25°C for 3hr.

Criteria: No fire, and no explosion.

### 9.2 External short-circuit test

Test method: To short-circuit the standard charged cell (or 50% discharged cell) by connecting positive and negative terminal by 80m $\Omega$  wire for 10min.

Criteria: No fire, and no explosion.

### 9.3 Reverse charge test

Test method: To charge the standard charged cell with charge current 10A  
By 0V for 2.5 hours.

Criteria: No fire, and no explosion.

### 9.4 Heating test

Test method: To heat up the standard charged cell at heating rate 5°C per minute up to 130°C and keep the cell in oven for 10 minutes.

Criteria: No fire, and no explosion.

## 10.0. Warranty

Samsung SDI will be responsible for replacing the cell against defects or poor workmanship for 18months from the date of shipping. Any other problem caused by malfunction of the equipment or mix-use of the cell is not under this warranty.

The warranty set forth in proper using and handling conditions described above and excludes in the case of a defect which is not related to manufacturing of the cell.

## 11.0. Others

### 11.1 Storage for a long time

If the cell is kept for a long time (3 months or more), It is strongly recommended that the cell is preserved at dry and low-temperature.

### 11.2 Others

Any matters that specifications do not have, should be conferred with between the both parties.

## 12.0. Packing

See Fig.2,  
Package Drawing

Spec. No.	INR18650-25R	Version No.	1.0	In-Young Jang
-----------	--------------	-------------	-----	---------------

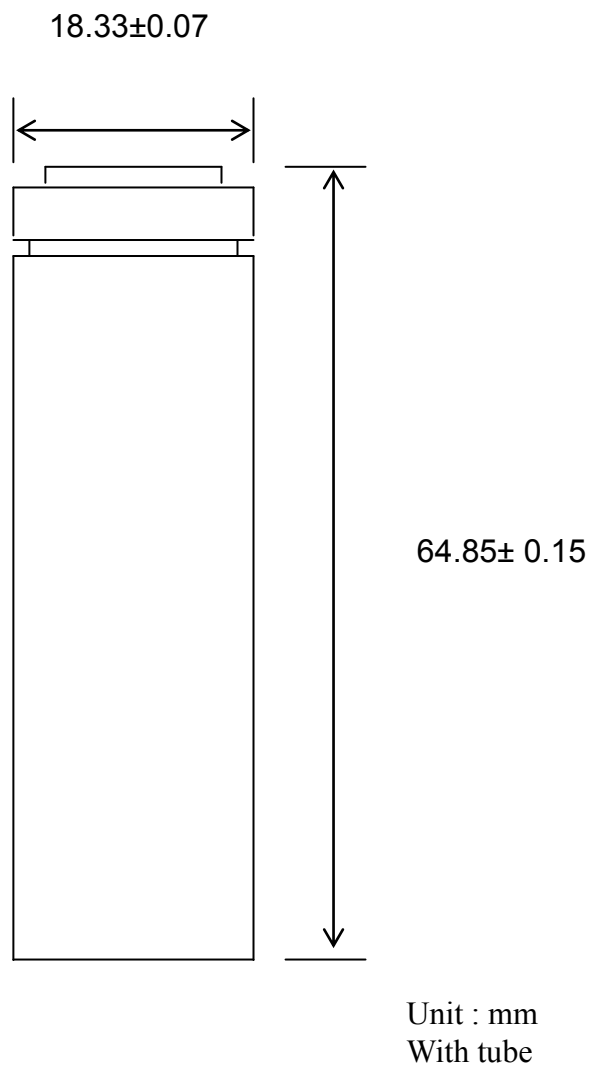

**Fig.1. Outline dimensions of INR110500-25R**

Spec. No.	INR18650-25R	Version No.	1.0	In-Young Jang
-----------	--------------	-------------	-----	---------------

NO	PART NAME	MATERIAL	MATERIAL DIM	QTY
01	INR18650(Ref. Model List)	BARE CELL	#18, H65	200
02	PACKING GUIDE	MANILA	L192×W191×H67	200
03	PACKING CASE IN	SW-1(B FLUTE)	L192×W192×H68	2
04	SILICAGEL	SI	L50×W50.3G	2
05	PE BAG(LARGE)	PE	L500×W450×T0.028	1
06	TAPE	PE(OPP)	W50×T0.05	1
07	PACKING CASE OUT	DW-1(BA FLUTE)	L225×W214×H164	1
08	LABEL	ART PAPER	L52×W100	1

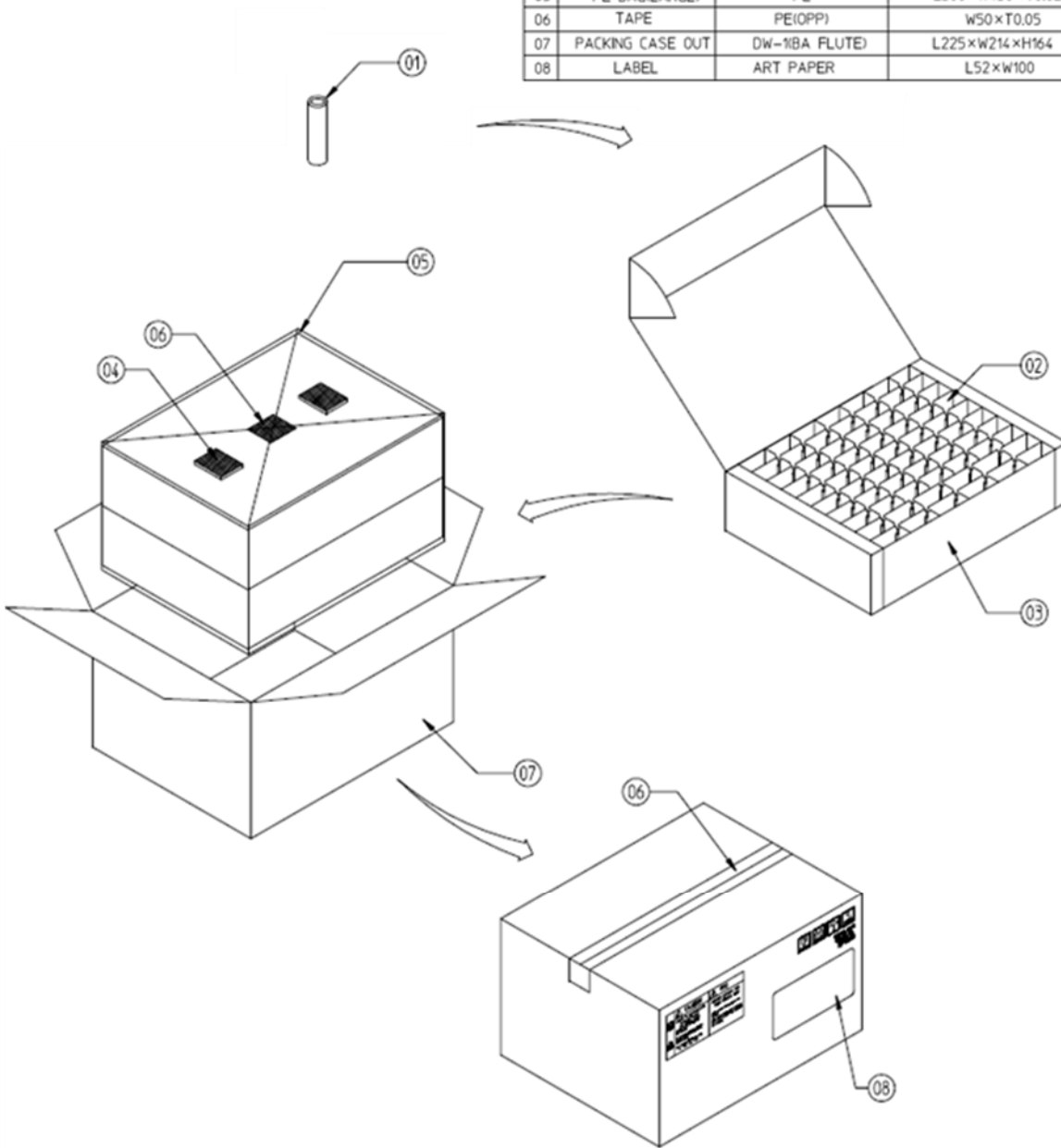

**Fig.2. Package drawing**



Spec. No.	INR18650-25R	Version No.	1.0	In-Young Jang
-----------	--------------	-------------	-----	---------------

## **Proper use and handling of lithium ion cells**

See before using lithium-ion cell

Supplied by

**Samsung SDI Co., Ltd.**

### **1.0. General**

This document has been prepared to describe the appropriate cautions and prohibitions, which the customer should take or employ when the customer uses and handles the lithium ion cell to be manufactured and supplied by Samsung SDI Co., Ltd., in order to obtain optimal performance and safety.

### **2.0. Charging**

#### 2.1 Charging current

Charging current shall be less than maximum charge current specified in the product specification.

#### 2.2 Charging voltage

Charging shall be done by voltage less than that specified in the product specification.

#### 2.3 Charging time

Continuous charging under specified voltage does not cause any loss of performance characteristics. However, the charge timer is recommended to be installed from a safety consideration, which shuts off further charging at time specified in the product specification.

#### 2.4 Charging temperature

The cell shall be charged within a range of specified temperatures in the specification.

#### 2.5 Reverse charging

The cell shall be connected, confirming that its poles are correctly aligned.

Inverse charging shall be strictly prohibited. If the cell is connected improperly, it may be damaged.

### **3.0. Discharging**

#### 3.1 Discharging

3.1.1 The cell shall be discharged continuously at less than maximum discharge current specified in the product specification. In case of the higher discharge current should be set, it shall be discussed together with SDI.

#### 3.2 Discharging temperature

3.2.1 The cell shall be discharged within a range of temperatures specified in the product specification.

3.2.2 Otherwise, it may cause loss of performance characteristics.

#### 3.3 Over-discharging

3.3.1 The system should equip with a device to prevent further discharging exceeding discharging cut-off voltage specified in the product specification.

3.3.2 Over-discharging may cause loss of performance characteristics of battery.

3.3.3 Over-discharging may occur by self-discharge if the battery is left for a very long time without any use.

3.3.4 The charger should equip with a device to detect voltage of cell block and to determine recharging procedures.

### **4.0. Storage**

#### 4.1 Storage conditions

Spec. No.	INR18650-25R	Version No.	1.0	In-Young Jang
-----------	--------------	-------------	-----	---------------

4.1.1 The cell should be stored within a range of temperatures specified in the product specification.

4.1.2 Otherwise, it may cause loss of performance characteristics, leakage and/or rust.

#### 4.2 Long-term storage

4.2.1 The cell should be used within a short period after charging because long-term storage may cause loss of capacity by self-discharging.

4.2.2. If long-term storage is necessary, the cell should be stored at lower voltage within a range specified in the product specification, because storage with higher voltage may cause more loss of performance characteristics.

### 5.0. Cycle life

#### 5.1 Cycle life performance

5.1.1 The cell can be charged/discharged repeatedly up to times specified in the product specification with a certain level of capacity specified in the product specification.

5.1.2 Cycle life may be determined by conditions of charging, discharging, operating temperature and/or storage.

### 6.0. Design of system

#### 6.1 Connection between the cell and the battery

6.1.1 The cell should not be soldered directly with other cells. Namely, the cell should be welded with leads on its terminal and then be soldered with wire or leads to solder.

6.1.2 Otherwise, it may cause damage of component, such as separator and insulator, by heat generation.

#### 6.2 Positioning the battery in the system

6.2.1 The battery should be positioned as possible as far from heat sources and high temperature components.

6.2.2 Otherwise, it may cause loss of characteristics.

6.2.3 The recommended spacing between the cells is more than 1mm.

#### 6.3 Mechanical shock protection of the battery

6.3.1 The battery should be equipped with appropriate shock absorbers in the pack in order to minimize shock, which can damage the cells.

6.3.2 Otherwise, it may cause shape distortion, leakage, heat generation and/or rupture and/or open circuit.

#### 6.4 Short-circuit protection of the cell

6.4.1 The cell equips with an insulating sleeve to protect short-circuit which may occur during transportation, battery assembly and /or system operation.

6.4.2 If the cell sleeve is damaged by some cause such as outside impact, it may cause short-circuit with some wiring inside the battery.

#### 6.5 Connection between the battery and charger/system

6.5.1 The battery should be designed to be connected only to the specified charger and system.

6.5.2 A reverse connection of the battery, even in the specified system, should be avoided by employing special battery design such as a special terminals.

#### 6.6 Pack design

6.6.1 The current consumption of the battery pack should be under 10uA at sleep mode.

6.6.2 Cell voltage monitoring system.

The system (charger or pack) should be equipped with a device to monitor each

Spec. No.	INR18650-25R	Version No.	1.0	In-Young Jang
-----------	--------------	-------------	-----	---------------

voltage of cell block to avoid cell imbalance which can cause damage to the cells.

6.6.4 The battery pack or system should have warning system such as over temperature, over voltage, over current, and so on.

## 7.0. Battery pack assembly

7.1 Prohibition of usage of damaged cell

7.1.1 The cell should be inspected visually before battery assembly.

7.1.2 The cell should not be used if sleeve-damage, can-distorsion and/or electrolyte-smell is detected.

7.2 Terminals handling

7.2.1 Excessive force on the negative terminal should be avoided when external strip terminal is welled.

7.3 Transportation

7.3.1 If the cell is necessary to be transported to such as the battery manufacturer, careful precautions should be taken to avoid damage of cell.

## 8.0. Others

8.1 Disassembly

8.1.1 The cell should not be dismantled from the battery pack.

8.1.2 Internal short-circuit caused by disassembly may lead to heat generation and/or venting.

8.1.3 When the electrolyte is coming in contact with the skin or eyes, flush immediately with fresh water and seek medical advice.

8.2 Short-circuiting

8.2.1 Short-circuit results in very high current which leads to heat generation.

8.2.3 An appropriate circuitry should be employed to protect accidental short-circuiting.

8.3 Incineration

8.3.1 Incinerating and disposing of the cell in fire are strictly prohibited, because it may cause rupture and explosion.

8.4 Immersion

8.4.1 Soaking the cell in water is strictly prohibited, because it may cause corrosion and leakage of components to be damaged to functions

8.5 Mixing use

8.5.1 Different types of cell, or same types but different cell manufacturer's shall not be used, which may lead to cell imbalance, cell rupture or damage to system due to the different characteristics of cell.

8.6 Battery exchange

8.6.1 Although the cell contains no environmentally hazardous component, such as lead or cadmium, the battery shall be disposed according to the local regulations when it is disposed.

8.6.2 The cell should be disposed with a discharged state to avoid heat generation by an inadvertent short-circuit.

8.7 Caution

The Battery used in this device may present a risk of fire or chemical burn if mistreated.

Do not disassemble, expose to heat above 100°C or incinerate it.

Replace battery with those of Samsung SDI only.

Use of another battery may cause a risk of fire or explosion.

Dispose of used battery promptly.

Spec. No.	INR18650-25R	Version No.	1.0	In-Young Jang
-----------	--------------	-------------	-----	---------------

Keep battery away from children.

Do not disassemble and do not dispose of battery in fire.

## 8.8 Warning – Attached

### Handling precaution and prohibitions of lithium ion rechargeable cells and batteries

Inaccurate handling of lithium ion and lithium ion polymer rechargeable battery may cause leakage, heat, smoke, an explosion, or fire.

This could cause deterioration of performance or failure. Please be sure to follow instructions carefully.

#### 1.1 Storage

Store the battery at low temperature (below 25°C is recommended), low humidity, no dust and no corrosive gas atmosphere.

#### 1.2 Safety precaution and prohibitions

To assure product safety, describe the following precautions in the instruction manual of the application.

#### [ Danger! ]

##### ■ Electrical misuseage

Use stipulated charger.

Use or charge the battery only in the stipulated application.

Don't charge the battery by an electric outlet directly or a cigarette lighter charger.

Don't charge the battery reversely.

##### ■ Environmental misuseage

Don't leave the battery near the fire or a heated source.

Don't throw the battery into the fire.

Don't leave, charge or use the battery in a car or similar place where inside of temperature may be over 60°C.

Don't immerse, throw, wet the battery in water / sea water.

##### ■ others

Don't fold the battery cased with laminated film such as pouch and polymer.

Don't store the battery in a pocket or a bag together with metallic objects such as keys, necklaces, hairpins, coins, or screws.

Don't short circuit (+) and (-) terminals with metallic object intentionally.

Don't pierce the battery with a sharp object such as a needle, screw drivers.

Don't heat partial area of the battery with heated objects such as soldering iron.

Don't hit with heavy objects such as a hammer, weight.

Don't step on the battery and throw or drop the battery on the hard floor to avoid mechanical shock.

Spec. No.	INR18650-25R	Version No.	1.0	In-Young Jang
-----------	--------------	-------------	-----	---------------

Don't disassemble the battery or modify the battery design including electric circuit.

Don't solder on the battery directly.

Don't use seriously scared or deformed battery.

Don't put the battery into a microwave oven, dryer or high-pressure container.

Don't use or assemble the battery with other makers' batteries, different types and/or models of batteries such as dry batteries, nickel-metal hydride batteries, or nickel-cadmium batteries.

Don't use or assemble old and new batteries together.

### **[ Warning! ]**

Stop charging the battery if charging isn't completed within the specified time.

Stop using the battery if the battery becomes abnormally hot, order, discoloration, deformation, or abnormal conditions is detected during use, charge, or storage.

Keep away from fire immediately when leakage or foul odors are detected. If liquid leaks onto your skin or cloths, wash well with fresh water immediately.

If liquid leaking from the battery gets into your eyes, don't rub your eyes and wash them with clean water and go to see a doctor immediately.

If the terminals of the battery become dirty, wipe with a dry cloth before using the battery.

The battery can be used within the following temperature ranges. Don't exceed these ranges.

The operating temperature is based on the cell surface temperature in hottest position in pack.

Charge temperature ranges : 0℃ ~ 50℃

Discharge Temperature ranges : -20℃ ~ 75℃

Store the battery at temperature below 60℃

Cover terminals with proper insulating tape before disposal.

### **[ Caution! ]**

#### ■ Electrical misuseage

Battery must be charged with constant current-constant voltage (CC/CV).

Charge current must be controlled by specified value in cell specification.

Cut-off voltage of charging must be less than 4.2 + 0.05V

Charger must stop charging battery by detecting either charging time or current specified in cell's specification.

Discharge current must be controlled by specified value in cell's specification.

Cut-off voltage of full discharging and recharging must be over 2.5V.

#### ■ others

Keep the battery away from babies and children to avoid any accidents such as swallow.

Spec. No.	INR18650-25R	Version No.	1.0	In-Young Jang
-----------	--------------	-------------	-----	---------------

If younger children use the battery, their guardians should explain the proper handling method and precaution before using.

Before using the battery, be sure to read the user's manual and precaution of it's handling.

Before using charger, be sure to read the user's manual of the charger.

Before installing and removing the battery from application, be sure to read user's manual of the application.

Replace the battery when using time of battery becomes much shorter than usual.

Cover terminals with insulating tape before proper disposal.

If the battery is needed to be stored for an long period, battery should be removed from the application and stored in a place where humidity and temperature are low.

While the battery is charged, used and stored, keep it away from object materials with static electric chargers.

## **Safety handling procedure for the transporter**

### ■ Quarantine

Packages that are crushed, punctured or torn open to reveal contents should not be transported. Such packages should be isolated until the shipper has been consulted, provided instructions and, if appropriate, arranged to have the product inspected and repacked.

### ■ Spilled product

In the event that damage to packaging results in the release of cells or batteries, the spilled products should be promptly collected and segregated and the shipper should contact for instructions.

## **Design of positioning the battery pack in application and charger**

To prevent the deterioration of the battery performance caused by heat, battery shall be positioned away from the area where heat is generated in the application and the charger.

## **Design of the battery pack**

Be sure adopting proper safe device such as PTC specified type or model in Cell Specification. If you intend to adopt different safety device which is not specified in Cell Specification, please contact Samsung SDI to investigate any potential safety problem.

Be sure designing 2nd protective devices such as PCM at the same time to protect cell just in case one protective device is fault.

Please contact following offices when you need any help including safety concerns.

Spec. No.	INR18650-25R	Version No.	1.0	In-Young Jang
-----------	--------------	-------------	-----	---------------

Spec. No.	INR18650-25R	Version No.	1.0	In-Young Jang
-----------	--------------	-------------	-----	---------------

### Additional remarks

■ Cell package : The bare cell is packed by which packaging material, PET tube.

■ Model and tube marking : there are three lines on the cell tube as follows.

Line 1 : INR18650-25R --- cell model name

Line 2 : SAMSUNG SDI --- cell manufacturer

Line 3 : 2D51 --- date code (Capacity ; "2" is over 2.0Ah, Year, Month, Week)

■ Lot marking : There are three lines on the cell metal can as follows.

Line 1 : J5D5 --- 1<sup>st</sup> digit: Line number ( "1" for cylindrical line No.1, "J" for cylindrical line No. 8)

2<sup>nd</sup> digit: Final number of Model Name ("5" is INR18650-25x)

3<sup>rd</sup> digit: Year ( "D" is 2013)

4<sup>th</sup> digit: Month ( "5" is May ; A is Oct., B is Nov., C is Dec)

Line 2 : 45221 --- 1<sup>st</sup> digit: Negative coater number ( "7" is No. 7 coater)

2<sup>nd</sup> ~ 4<sup>th</sup> digit: Batch number

5<sup>th</sup> digit: Serial No. of assembling

Line 3 : 62F1 --- 1st digit: Date ("6" is 6th day ; 10 is A, 11 is B...)

2nd digit: Serial No. of winding in a batch

3rd digit: Reel No ( "F" is F reel ; A is A reel, B is B reel, ... F is F reel)

4th digit: Winding Machine No. ( "1" is No.1 winder)